

Instructions for Eltex EVG-s Yarn Break Sensors



EVG-s yarn break sensors are designed for general purpose use. They are robust, with a metal housing. The piezoelectric principle is used to detect the yarn movement (not presence). This working principle makes them suitable for all types of yarn and makes them insensitive to dust, dirt and humidity variations.

EVG-s sensors do not require a Central Control Unit, making them very cost effective.

Each sensor has a double modular jack, so they can easily be connected in parallel. The sensors can be used with a PLC or many other electronic devices like relays, I/O modules, etc.

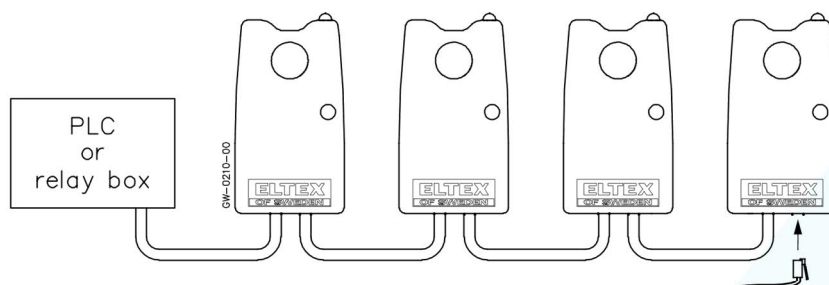

The 6P6C modular connectors on the sensors are connected electrically in parallel. Settings can be made via the touch button, with external push buttons or from a PLC.

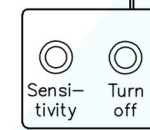

Optional. External push buttons.

NB! Yarn must have contact with the ceramic eyelet. The yarn movement will be best detected when the yarn deviates about 10–15° when it passes through the yarn sensor eyelet.

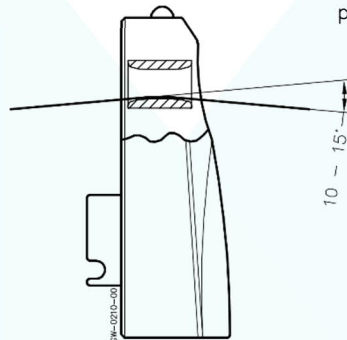

Modular jack pin configuration:

Pin	Wire colour	Use
1	White	Power supply, +17 – +30 V DC
2	Black	Output, optocoupler Emitter
3	Red	Output, optocoupler Collector
4	Green	Input, to inactivate sensor
5	Yellow	Input, to adjust sensitivity
6	Blue	Power supply, Ground 0 V *

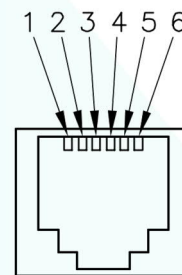

Modular jack

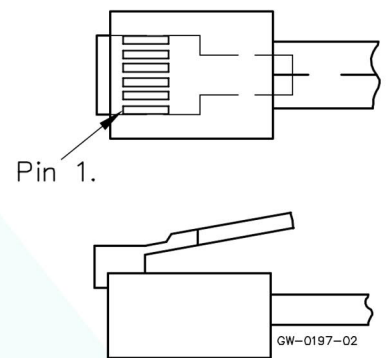

Modular cable with connector.

* **NB!** The negative supply must be connected to earth ground to provide proper shielding.

Connection with stripped cable:

(We recommend using a breakout board instead of stripping the cable)

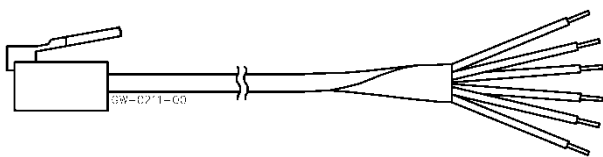

Pin	Colour	Use
1	White	Power supply, +17 – +30 V DC
2	Black	Output, optocoupler Emitter
3	Red	Output, optocoupler Collector
4	Green	Input, to inactivate sensor
5	Yellow	Input, to adjust sensitivity
6	Blue	Power supply, Ground 0 V

How to make the cable for connecting the sensors to each other:

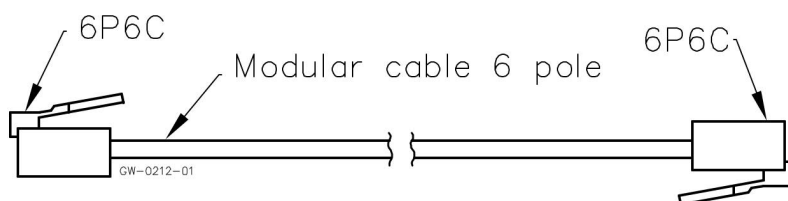

Align the cable this way before crimping.

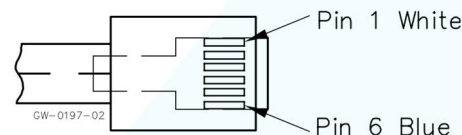

Typical connection to a relay

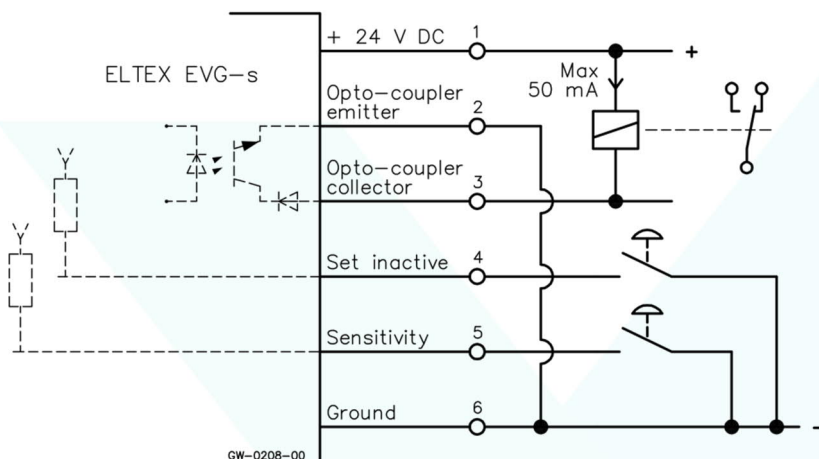

The relay will energise when there is no yarn movement, and the sensors are active.

When a relay output is required, we recommend to use the control unit Eltex FlexiHub 15781

Typical connection to a PLC

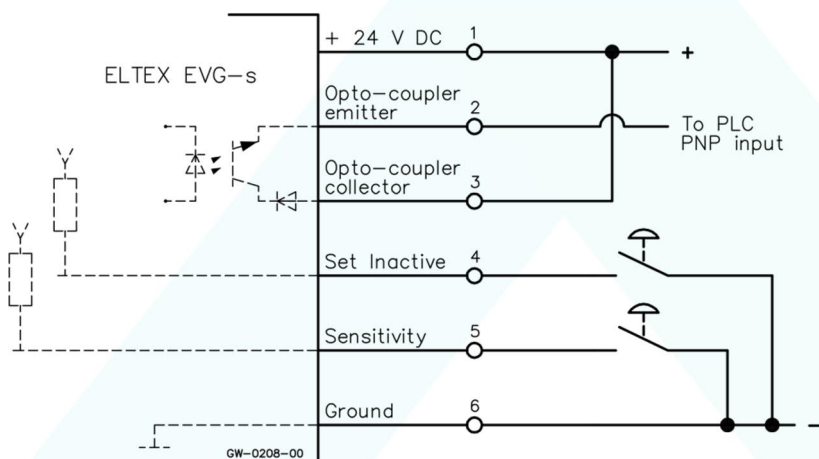

+24 V DC output when there is no yarn movement, and the sensors are active.

Sink inputs to ground
For more details see "Setting the sensor from a PLC" on page 4.

The LED indication

Flashing green	The sensor is active. No yarn movement is detected
Steady green	The sensor is active. Yarn movement is detected
Steady red	The sensor is inactive
Orange	When a button is pressed
Series of short red flashes	When in sensitivity setting mode: showing the actual sensitivity level

ON / OFF via the touch button

- When power is connected the sensor is active and during the first few seconds the LEDs are showing the current sensitivity setting.
- By momentarily pressing the touch button the sensor will be inactivated. The LEDs changes to red.
- When the sensor detects yarn movement for 7 seconds it automatically activates. The LEDs changes to green.

Setting the sensor's sensitivity via the touch button

The sensor's sensitivity (ability to detect the yarn movement) can be set in 8 levels. Level 1 is the least sensitive and level 8 is the most sensitive.

- Press and hold the touch button for 3 seconds. The LEDs briefly turn orange then begin to show the current setting with a series of red blinks.
- With each press of the touch button the sensitivity level will increase one level. After passing level 8 the setting returns to level 1.
- After 9 seconds of no input the sensor returns to normal mode and the new setting is saved.

Setting the sensor via the inputs in the modular jack

This can be done with external push buttons or from a PLC as per the following instructions.

Setting the sensor using external push buttons

A push button connected between ground and pin 4 and a push button connected between ground and pin 5 should be used.

- Inactivate the sensor by momentarily pressing the button connected to pin 4.
- The sensor's sensitivity (ability to detect the yarn movement) can be set in 8 levels. Level 1 is the least sensitive and level 8 is the most sensitive.
Enter the sensitivity setting mode by pressing and holding the button connected to pin 5 for 3 seconds.
Each time the button is pressed the sensitivity level is increased by one.
After passing level 8 the setting returns to level 1.
The sensor can also be reset to level 1 by pressing and holding the button for 2.5 seconds when in sensitivity setting mode.
- After 9 seconds of no input the sensor returns to normal mode and the new setting is saved.

The LED indication is the same as when making the settings via the touch button.

NB! When sensors are connected in parallel, the settings are made to all of them at the same time.

Setting the sensor from a PLC

Settings are made via the pins in the modular jack.

NB! When sensors are connected in parallel, the settings are made to all of them at the same time.

Activating and inactivating the sensor

- When power is first connected the sensor is active. The LEDs are green.
- Inactivate the sensor by momentarily sinking (grounding) pin 4. The LEDs changes to red. (Alternatively a +24V DC* pulse can be used).
- When the sensor detects yarn movement for 7 seconds it automatically activates. The LEDs changes to green.

Set the sensor's sensitivity.

The sensor's sensitivity (ability to detect the yarn movement) can be set in 8 levels. Level 1 is the least sensitive and level 8 is the most sensitive.

When the machine operator enters the sensitivity setting mode:

Program the PLC to sink pin 5 for 3 seconds to first enter the sensitivity setting mode, momentarily release, then sink pin 5 again for 2.5 seconds to reset all sensors to level 1.

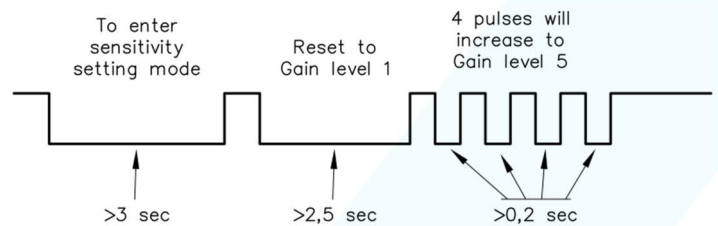

Next, give sink pulses on pin 5 corresponding to the sensitivity level selected by the operator. Duration of sink pulse should be a minimum of 200ms each.

(Alternatively +24V DC* pulses can be used).

After 9 seconds of no input the sensor returns to normal mode and the new setting is saved.

* =Not higher than the supply voltage.

Technical specification

Housing in zinc metal

Power supply

+17 – +30 V DC smoothed ripple.

NB! The negative supply must be connected to earth ground to provide proper shielding.

Current consumption

Max. 15 mA

Output function

Optocoupler output:

The optocoupler is open (off) when the sensor is on and the yarn is moving and also when the sensor is off.

The optocoupler is closed (on) when the sensor is on and the yarn is not moving.

Max. load on output

50 mA

Reaction time

120 ms

Sensors connected together

Not more than 70 sensors should be connected in one chain.

For larger applications the Eltex EYE System is recommended.

We reserve the right to modify design and technical data

