

Thread sensor

15965, for sewing machines

INFO LEAFLET



This thread sensor is designed to monitor up to 6 intermittent running threads on automatic sewing machines. The eyelets are scanned electronically. It detects both broken and continuously moving threads.

The yarn movement can be monitored even when the yarn tension is rather low. This sensor has optocoupler input and output and is suitable for machines with PLC control system.

■ Technical features

- The thread sensor works on the piezo electric principle and the thread stitch pulses are detected by the eyelet.
- For each eyelet there is an ON/OFF switch.
- Each eyelet has a red LED to indicate a stop.
 - A broken thread is indicated by continuous light on the LED.
 - A continuous moving thread is indicated by the LED flashing.
- A green LED on the thread sensor indicates when the sensor is active and sensing the yarns.
- Power supply 24 V (16–33V) DC.
Current consumption 35 mA.
- The thread sensor has a M12 connector.

■ Function

The thread sensor can be used on a PLC control system.

The PLC should be programmed to give a signal on the optocoupler input when the sewing machine is running and the threads must be moving.

The thread sensor sends a stop on the optocoupler output if any yarn is not moving correctly during the time the thread sensor is active.



■ Adjustments

- Sensitivity to the thread movement can be adjusted by the GAIN potentiometer accessible from the outside of the thread sensor.
- It is possible to adjust the reaction time. This can be done easily with a potentiometer available under the lid inside the thread sensor.
- On a slow operating machine it may be necessary to make the reaction time longer.
- On a high speed machine, the time can be set shorter than standard to stop the machine quickly if so desired.

■ Dimensions

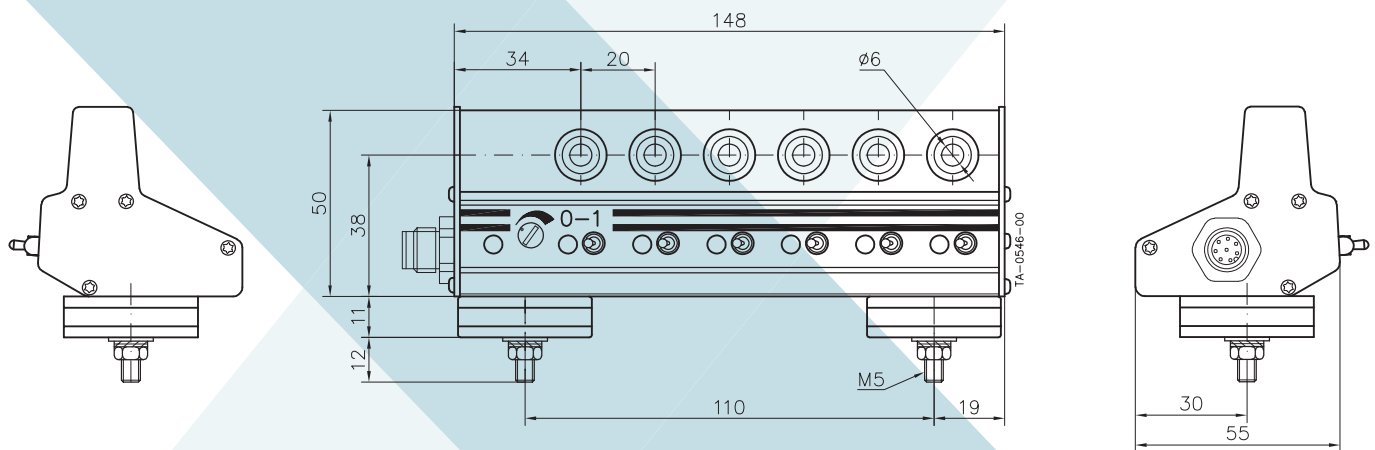

Södra Portgatan 19, SE-283 50 OSBY, Sweden | Tel: +46 479 536300 | Email: info@eltex.se | www.eltex.se

Eltex U.S., Inc.
13031 E. Wade Hampton Blvd.,
GREER, South Carolina, 29651, USA
Tel: +1 864-879-2131
Email: sales@eltexus.com

Eltex Manufacturing Ltd.
Railway Road,
TEMPLEMORE, Co. Tipperary, Ireland
E41HX65
Tel: +353 504-314 33

POLSA-ELTEX, S.L.
Zamora, 103 – entlo 3o,
ES-08018 BARCELONA, Spain
Tel: +34 93 309 00 17
Email: polsa@infonegocio.com

Eltex China (Beijing) Trading Ltd.
HongkunYun Times B4 207,
Yizhuang Kechuang 12th street,
Daxing, Beijing, China
Tel: +86 10 6506 6468
Email: chuan.jiang@eltex.cn
Web: www.eltex.cn